



**51.2V280Ah-14.3KWH
Energy Storage System Installation Manual**

1. Product Overview

This product is a household energy storage system that meets various electricity needs in daily household life. Through reasonable charging and discharging strategies, it reduces electricity costs while ensuring the stability and reliability of electricity use.

1.1 Appearance

1.1.1 Output and communication terminals

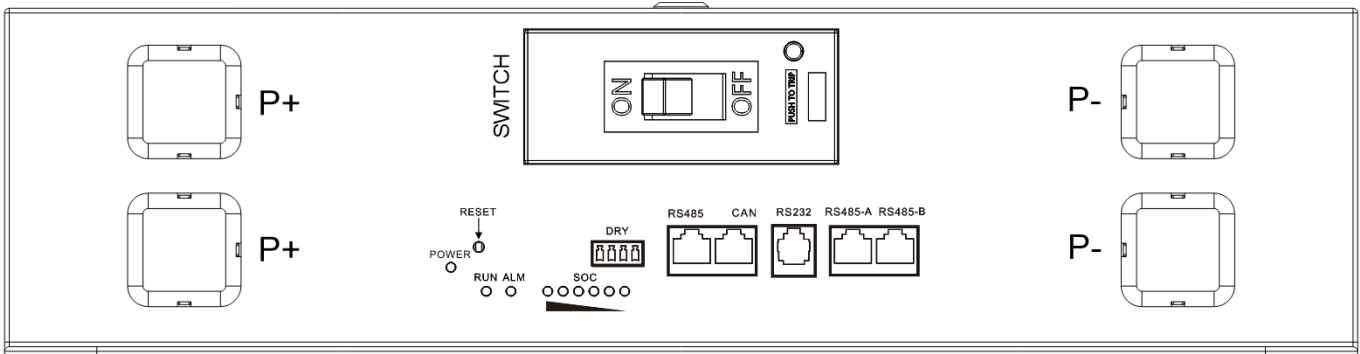

1.1.2 Wall-mounted Installation dimensions

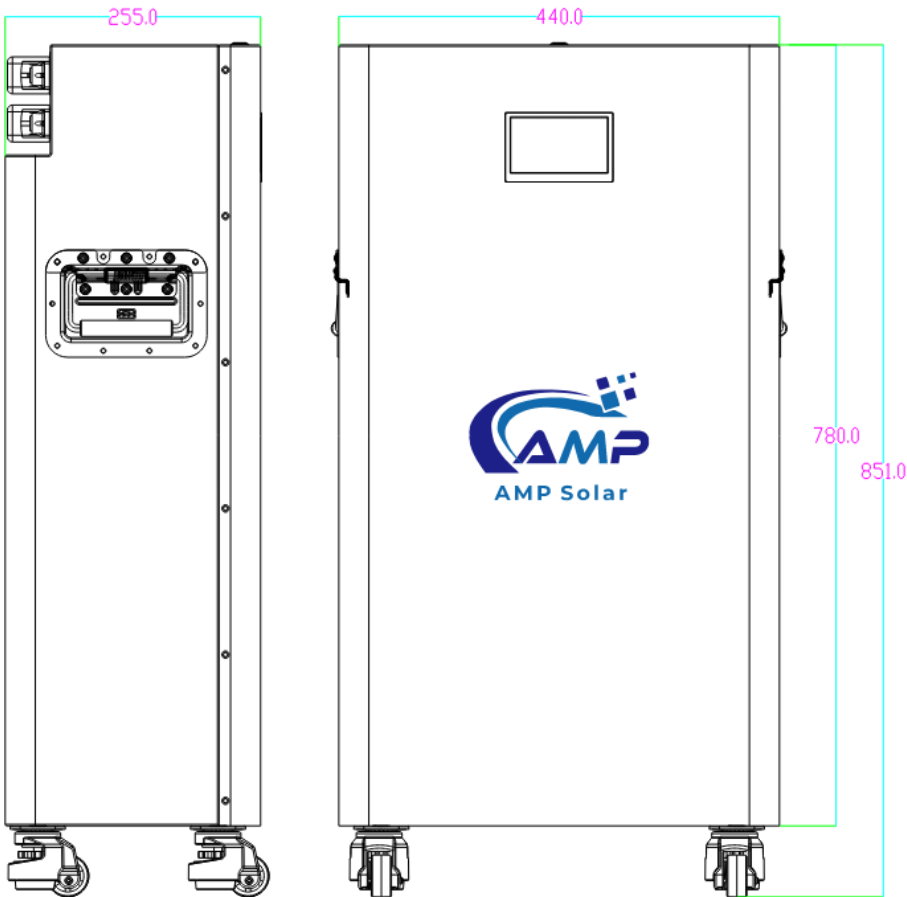

2. Display and port functions

2.1 Buttons, liquid crystal display, LED indicators and communication interfaces

2.1.2 Automatic parallel encoding

2.1.2.1. Turn off the battery first and then connect the positive and negative parallel wires of the battery → Connect the battery pack communication parallel wires (the first 485A port is connected to the second 485B port, and so on, the last one is the host) → After connecting the wires, start the machines one by one starting from the last host.

2.1.3 Button Functions

2.1.3.1 Turning on output

The two ON/OFF buttons in function diagram 1 turn on the battery output. If multiple units are connected in parallel, connect the communication parallel lines and then press the button to turn on the battery output.

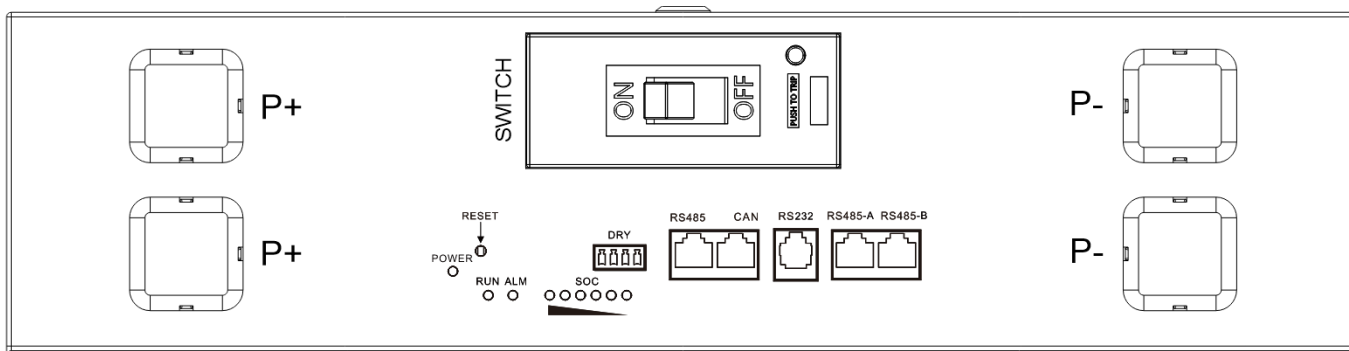
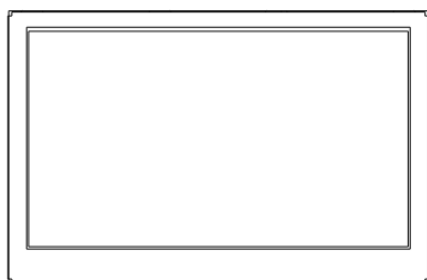

Functional diagram 1

2.1.4 LED indicators and communication ports

2.1.4.1 LED indicators:

In the power-on state, the LED indicators of function diagram 2, POWER is the green power indicator, RUN is the green normal operation indicator, ALM is the red alarm indicator, and the 6 SOC green indicators indicate the battery power.

LED indication instructions

Table 1 LED working status indication

State	Normal/Alarm/ Protection	ON/ OFF	RUN	ALM	SOC LED						Description	
		●	●	●	L6	L5	L4	L3	L2	L1		
		●	●	●	●	●	●	●	●	●		
Shut down	Sleep	OFF	OFF	OFF	OFF	OFF	OFF	OFF	OFF	OFF	OFF	All OFF
Standby	Normal	ON	Flash1	OFF	Subjecting to the indication						Standby state	
	Alarm	ON	Flash1	Flash3							Module Low Voltage	
charging	Normal	ON	ON	OFF	Subjecting to the indication (Power indicator maxi LED flashes 2)						The highest battery LED flashes (F ②), and the ALM does not flash when there is an overcharge alarm	
	Alarm	ON	ON	Flash3								
	Overcharge protection	ON	ON	OFF	ON	ON	ON	ON	ON	ON	ON	If there is no mains power, the indicator light will switch to standby mode
	Temperature, over-current, failure protection	ON	OFF	ON	OFF	OFF	OFF	OFF	OFF	OFF	OFF	Stop charging
Discharging	Normal	ON	Flash3	OFF	Subjecting to the indication							
	Alarm	ON	Flash3	Flash3								
	Under-voltage protection	ON	OFF	OFF	OFF	OFF	OFF	OFF	OFF	OFF	OFF	Stop charging
	Temperature, overcurrent, short circuit, reverse connection, failure protection	ON	OFF	ON	OFF	OFF	OFF	OFF	OFF	OFF	OFF	Stop charging
fault		OFF	OFF	ON	OFF	OFF	OFF	OFF	OFF	OFF	OFF	Stop charging& discharging

Table 2 Capacity Indication Description

State		Charging						Discharge					
Capacity indicator light		L6 ●	L5 ●	L4 ●	L3 ●	L2 ●	L1 ●	L6 ●	L5 ●	L4 ●	L3 ●	L2 ●	L1 ●
SOC	0% ~ 17%	OFF	OFF	OFF	OFF	OFF	Flash 2	OFF	OFF	OFF	OFF	OFF	ON
	18% ~ 33%	OFF	OFF	OFF	OFF	Flash 2	ON	OFF	OFF	OFF	OFF	ON	ON
	34% ~ 50%	OFF	OFF	OFF	Flash 2	ON	ON	OFF	OFF	OFF	ON	ON	ON
	51% ~ 66%	OFF	OFF	Flash 2	ON	ON	ON	OFF	OFF	ON	ON	ON	ON
	67% ~ 83%	OFF	Flash 2	ON	ON	ON	ON	OFF	ON	ON	ON	ON	ON
	84% ~ 100%	Flash 2	ON	ON	ON	ON	ON	ON	ON	ON	ON	ON	ON
● Operation indicator		ON						Flashing (Flash 3)					

2.1.4.1 Communication Ports:

The two RJ45 interfaces RS485 and CAN are arranged in parallel on the left side of functional diagram 1. These two are the communication interfaces between the battery and the photovoltaic inverter. When the battery is the host, it can aggregate the data of the slaves and communicate with the inverter. The baud rate of RS485 communication is 9600 bps by default , and the frequency of CAN communication is 500K by default.

The two RJ45 interfaces RS485-A and RS485-B are arranged in parallel on the right side of functional diagram 1.

These two are the parallel RS485 communication interfaces of the battery. The baud rate is 9600 bps by default . If you need to communicate with the monitoring device via RS485 , the monitoring device acts as the host and polls data based on the address. The address setting range is 2~15 .

The RJ11 interface in the middle of Function Diagram 1 is the R232 communication terminal of the battery BMS.

BMS can communicate with the host computer through the RS232 interface , so that the host computer can monitor various information of the battery, including battery voltage, current, temperature, status and battery production information, etc. The default baud rate is 9600bps.

2.1.5 Dry Contact Port

In the function diagram 1, DRY is a dry contact port . BMS can send information such as temperature protection signals to monitoring and load devices through dry contacts , thereby controlling the output of load devices or the execution of related functions by monitoring devices.



2.1.6 Battery output terminal

In the functional diagram 1, P+ and P- are the positive and negative outputs of the battery PACK, which are used as high-power output and high-power charging input.

The positive and negative terminals support 200A continuous current: M8 screw / 200A / red is positive / black is negative

2.2 Bluetooth / WIFI function

2.2.1 Reset Bluetooth and add new Bluetooth devices

Press the RESET button in function diagram 2 for 10-13 seconds. After all the SOC lights are on, only RUN light is on. Release the RESET button (except the ON/OFF light). Wait for 8 seconds and then can see the new device in the APP Add Devices section.

2.2.2 WiFi Function

2.2.2.1 WiFi communication

Press the RESET button in function diagram 2 for 10-13 seconds. After all the SOC lights are on, only RUN light is on. Release the RESET button (except the ON/OFF light). Wait for 8 seconds and then can see the new device in the APP Add Devices section.

2.2.2.2 Download APP

Select the download link according to your phone system :

Android: <https://play.google.com/store/apps/details?id=com.paicheng.bms>

iOS: <https://apps.apple.com/cn/app/6461723294>

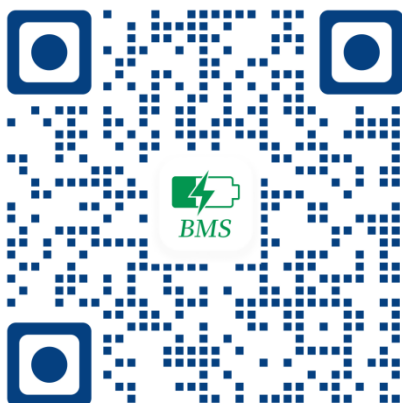

2.3 Communication port definition

2.3.1 RS485/CAN and inverter (PCS) interface

RS485 CAN RS232 RS485-A RS485-B

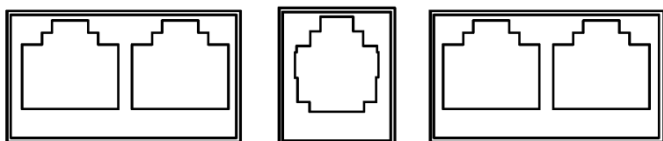

2.3.2 RS485 battery PACK parallel communication interface (RS485A/RS485B)

CAN--Using 8P8C vertical RJ45 socket		RJ485--Using 8P8C vertical RJ45 socket	
RJ45 PIN	Definition	RJ45 PIN	Definition
1、 3、 6、 7、 8	NC	9、 16	RS485-B1
4	CAN-H	10、 15	RS485-A1
5	CAN-L	11、 14	GND
2	GND	12、 13	NC

CAN & RS485 interfaces

RJ485--Using 8P8C vertical RJ45 socket		RJ485--Using 8P8C vertical RJ45 socket	
RJ45 PIN	Definition	RJ45 PIN	Definition
1、 8	RS485-B	9、 16	RS485-B
2、 7	RS485-A	10、 15	RS485-A
3、 6	GND	11、 14	GND
4、 5	NC	12、 13	NC

Parallel communication port

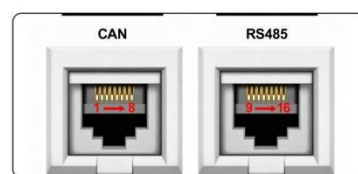

CAN and RS485 interfaces



Parallel communication ports

2.3.3 RS232 battery pack and PC communication interface



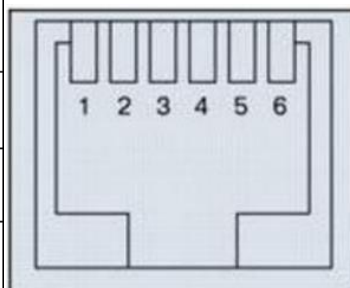

RS232--Using 6P6C vertical RJ11 socket	
RJ11 PIN	Definition
1、 2、 6	NC
3	TX (on-board)
4	RX (on-board)
5	GND

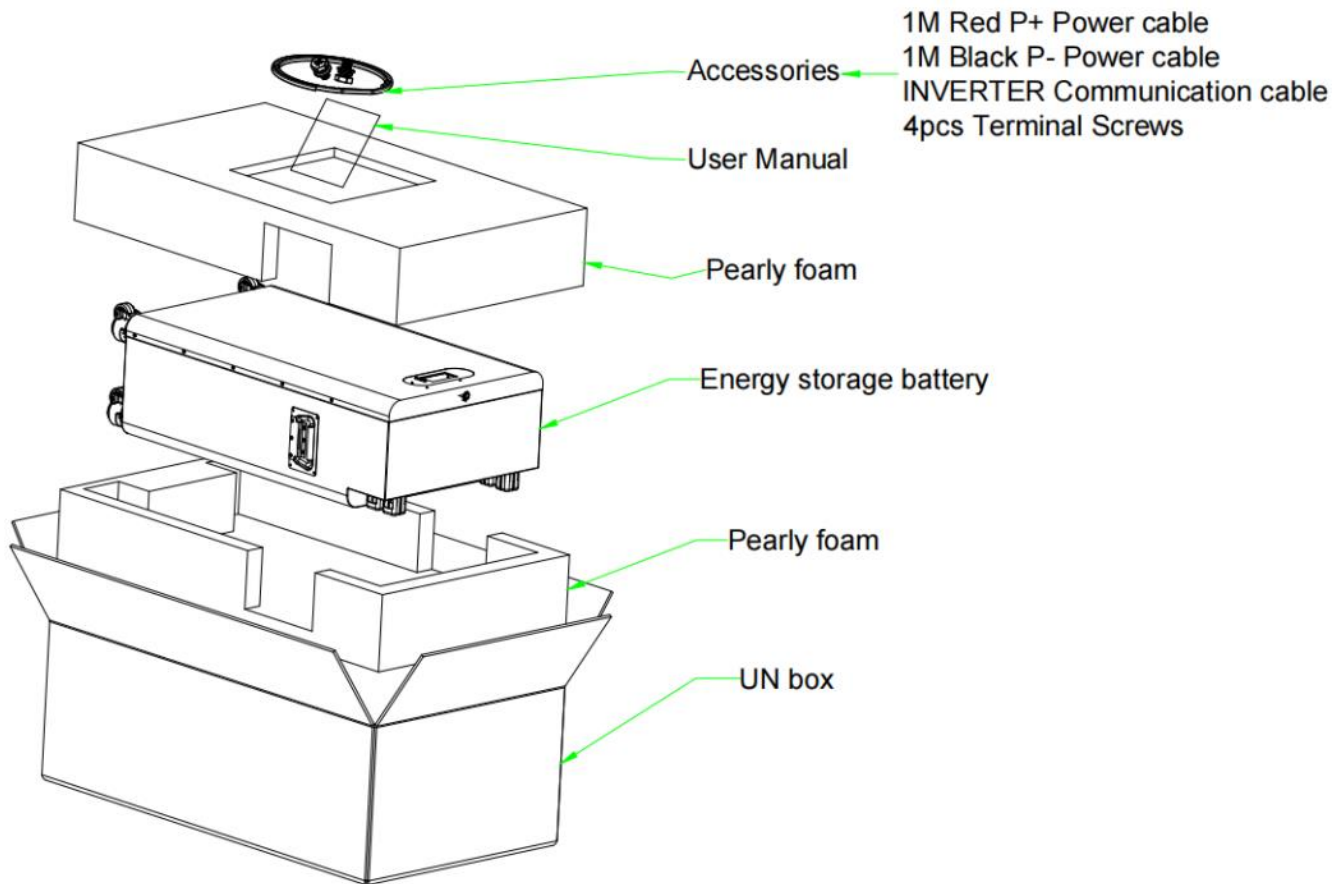

3. Installation Guide

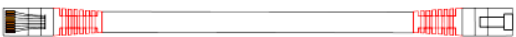
3.1 Check the product and install the accessories

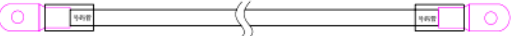

No	PICS	QTY	Describe
1		1	Battery pack
2		1	Communication cable
3		1	PCS P+connector cable
4		1	PCS P-connector cable
5		1	M8*16 screw
6		1	User manual

3.2 Installation tools and protective equipment

Installation Tools	刀  knife	卷尺  Tape measure	套筒扳手  socket spanner
	锤子  hammer	十字螺丝刀  cross screwdriver	冲击钻/锤钻  Impact drill/Hammer drill
Protective equipment	静电防护手套  Electrostatic protection gloves	护目镜  Goggles	安全鞋  Safety shoes

3.3 Installation Instructions

Minimum installation distance requirement: (wall-mounted)

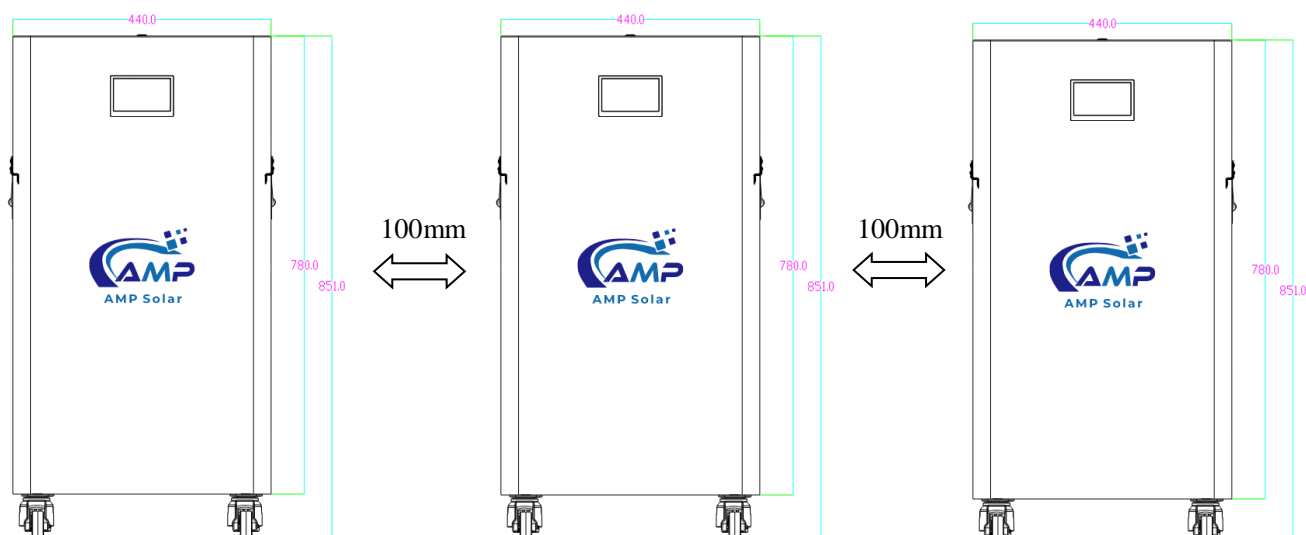

3.4 Installation Steps

3.4.1 Step 4

3.4.1 First install the energy storage battery in an open and suitable place, where there is no exposure to the sun, rain, moisture, etc., then turn off the ON/OFF switch and disconnect the battery output before installing it.

3.4.2 The battery P+ is connected to the negative pole of the inverter, the P+ is connected to the positive pole of the inverter, and the RS485/CAN is connected to the inverter communication, as shown in the following installation diagram:

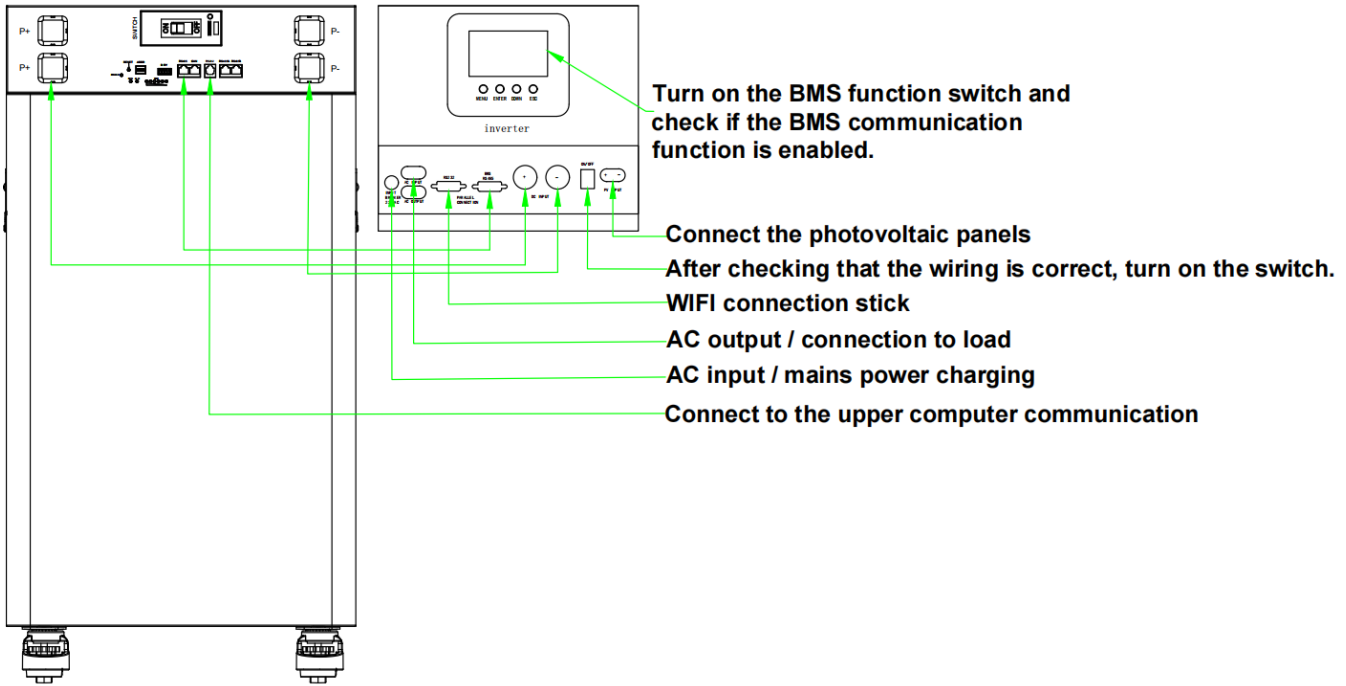

3.4.3 Multiple units parallel installation, as shown below:

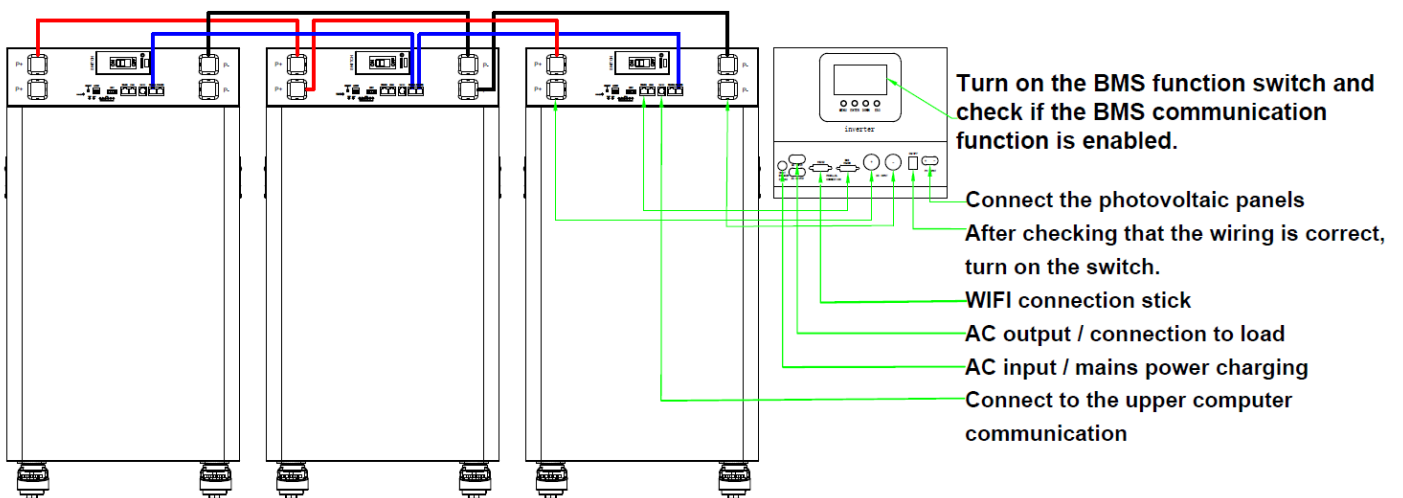

4. Inverter Protocol Catalog List

4.1 Inverter protocol for battery pack

Home Storage Product Inverter Protocol	
PACE :	
1	000-PACE_RS232_UN
2	000-PACE_RS485_MS_UN
RS485 :	
1	000-PACE_RS485_Modbus_UN
2	001-PYLON RS485 LV V3.5-2019.12.23--9600
3	002-Growatt RS485 V2.02-2019.07.24
4	003-Voltronic RS485 Inverter V1.5-2022.01.18
5	012-Luxpowertek RS485 Inverter V0.3-2020.07.06
6	036-WOW RS485 Modbus V1.3-2017.06.27
7	015-Schneider V2.0
CAN :	
1	001-PYLON CAN Inverter EMS
2	002-Growatt CAN LV V1.05-2019.08.28
3	010-Victron CAN 2021.01.07
4	015-Schneider CAN V2.0
5	012-Luxpowertek CAN V1.0-2020.02.11
6	013-Sorotec CAN Inverter V1.0
7	017-SMA CAN V2.0 (SMA)
8	007-GoodWe CAN Inverter LV V1.7-2020.02.28
9	035-STUDER CAN V1.02-2018.06.14
10	030-MUST CAN PV1800F
11	014-GINLONG CAN LV V1.0-2019.12.28
12	028-Senergy CAN V1.1-2022.05.10
13	033-TBB CAN V1.05-2021.04.20
14	031-MEGAREVO CAN Inverter LV V1.1

5. Technical Specifications

Basic Project	parameter
Battery Type	Lithium Iron Phosphate
Nominal voltage	51.2V
Nominal capacity	280Ah
Nominal energy	14336Wh
Charging voltage	57.6V ±0.025V
Charging Current	Standard (0.5C)140A , maximum 200A
Discharge voltage range	40V ~ 57.6V
Discharge current	Standard (0.5C)140A, maximum 200A
Communication Mode	CAN/RS485/RS232
Operating temperature	Charging 0~45°C, discharging -20~60°C
Storage temperature and temperature	65%RH (non-condensing), -10~45°C
Product size	850 * 440 *255 mm (excluding handles, terminals, and ears)
weight	120kg

IP protection rating	IP30
----------------------	------

6. Battery Maintenance

6.1 Supplementary power requirements during storage

The battery should be stored in a temperature range of -20~+45°C and charged regularly at 0.2C (20A) according to the following table. After long-term storage, the battery should be recharged to 50% capacity .

Storage temperature	Storage relative humidity RH	Storage time	SOC power
Below -10 °C		Not allowed	
-10~0°C	5%~65%	≤ 1 month	30 % ≤SOC≤60 %
0~25 °C	5%~65%	≤ 1 2 months	30 % ≤SOC≤60 %
20~35 °C	5%~65%	≤ 6 months	30 % ≤SOC≤60 %
35~45°C	5%~65%	≤ 1 month	30 % ≤SOC≤60 %
Above 45 °C		Not allowed	

6.2 Over discharge supplementary power requirements

Please charge the over-discharged (90% DOD) battery according to the following table, otherwise the over-discharged battery will be damaged .

Storage temperature	Storage time	Precautions
-1 0~ 2 5 °C	≤ 15 days	Battery disconnect inverter
25 ~45 °C	≤ 7 days	
-10 ~45 °C	≤ 12 hours	Battery connection inverter

6.3 Disposal of batteries should comply with local regulations.

6.4 Notes

6.4.1 Warranty

The Manufacturer will be responsible for replacing the battery pack against defects or poor workmanship for 5years from the date of shipping . Any other problem caused by malfunction of the equipment or misuse of the battery is battery is not covered under this warranty.

6.4.2 For Safety

- Do not disassemble packs.
- Do not use pack when something abnormal found such as smells, deformation, discoloration, and so on.
- Do not re-use LiFePO4 cells or other parts after removing from the packs.
- When the electrolyte leakage occurs, do not touch the liquid.
- Once watered, packs may have potential malfunctions. Do not use those packs.
- Do not have packs in the hot-temperature (60°C or more).

- g. Do not put packs into fire.
- h. Do not crush/nail pack.
- i. Do not apply solder directly to packs.